

EUROPRO

USER MANUAL SINGLE-PHASED COMPRESSORS EUROPRO 25 & 27

Ref. 90034 & 91327



EUROPE PROJECTION - 228, avenue Olivier Perroy 13790 ROUSSET
Tél : +33 (0)4 42 29 08 96 – Fax : +33 (0)4 42 53 44 36
SAS au capital de 400 000€ - SIREN 394 961 510 – NAF 2892 Z

Edition du 12/02/2019

SUMMARY

1. INTRODUCTION	p. 4
2. USER MANUAL	p. 5
2.1. Importance of the manual	p. 5
2.2. Receivers of the manual	p. 5
3. WARNING	p. 6
3.1. Safety	p. 6
3.2. Electric connection	p. 8
3.3. End-of-life of the product	p. 8
4. YOUR COMPRESSOR	p. 9
4.1. Description	p. 9
4.2. Technical characteristics	p. 9
4.3. Identification of the components EUROPRO 25	p.10
4.3. Identification of the components EUROPRO 27	p.11
5. USE OF THE MACHINE	p.12
5.1. Prerequisites	p.12
5.2. Starting up	p.12
5.3. Stopping of the compressor	p.12
6. MAINTENANCE AND SERVICING	p.13
6.1. Once per week	p.13
6.2. Every 200 working hours	p.13
7. DEFECTS AND REMEDIES	p.14
8. DECLARATION OF CONFORMITY	p.16
9. WARRANTY	p.17
9.1. Warranty conditions	p.17
9.2. Warranty certificate	p.19

1. INTRODUCTION

You just acquired a **single-phased compressor** and all the team of Europe Projection thanks you for the confidence you have granted us.

Manufacturer of professional equipments for paint and fillers, we have put our know-how for 20 years at the service of the users of our machines.

Our technical and commercial team is at your disposal for any further information you may need about the machine you just acquired.

EUROPE PROJECTION

228, avenue Olivier Perroy 13790 ROUSSET

Tél : +33 (0)4 42 29 08 96 – Fax : +33 (0)4 42 53 44 36

SAS au capital de 400 000€ - SIREN 394 961 510 – NAF 2892 Z

2. USER MANUAL

2.1. IMPORTANCE OF THE MANUAL

This manual is a key part for the use of your machine. It summarizes the procedures of starting-up, cleaning and maintenance of the device and also the safety instructions you need to observe.

Read carefully all the working and safety instructions and the warnings included in this manual before starting your machine.

Most of the accidents are caused by the non-compliance of the safety standards and rules.

This manual must be kept near the machine, within reach of the user and held in good condition until the final destruction of the machine.

In case of loss or deterioration of the manual, you can ask the machine manufacturer mentioned on page 4 for a copy at any moment.

2.2. RECEIVERS OF THE MANUAL

This manual is intended to any staff which will manipulate the machine :

- people in charge of the transport of the machine
- people in charge of the use of the machine
- people in charge of the cleaning and maintenance of the machine
- people in charge of the final destruction of the machine

3. WARNING

3.1. SAFETY

Using the machine in an incorrect way or in non-compliance of the safety instructions indicated in this manual can cause death or serious injuries.

Read carefully all the working and safety instructions and the warnings contained in this manual before starting your machine.



- Respect all the safety standards before running the equipment.
- Use the equipment only for the applications specified in the manual.
- Always remain alert when using the equipment.
- Transport the machine using the handles or the appropriate grips.
- During the breaks, disconnect electrically the machine.



- Run the equipment to its nominal voltage.
- Let at least 50 cm of free space between the equipment and any obstacle so that the air flow is not blocked.
- Know how to quickly stop the equipment in case of necessity.
- Never use the equipment while it is running abnormally or it is defective.
- Do not direct a water jet or flammable liquid on the compressor.
- Never direct an air jet or product jet on a person or an animal.
- Do not touch warm surfaces of the equipment.
- Always wear adequate body protections (glasses, gloves, overall and mask) and pay attention to long hair.
- Never touch moving parts.
- Do not insert any object or the hands inside the protection grids to avoid any accident or damage to the machine.
- For any outside job, only use appropriate extension cords.



- Maintain the equipment carefully and clean it properly after every use.
- Disconnect the equipment before any intervention.
- Avoid absolutely to unscrew any connection while the machine is under pressure.
- Check the damaged parts.
- Do not clean the plastic parts with solvent.
- In case of damage of the electric cable or the plug, do not run the machine and contact a licensed After-Sale Service to put genuine parts instead of the defective ones.
- In case of needed After-Sale Service, always specify the machine model and its serial number.
- For any replacement of parts, only use genuine parts.

3. WARNING (continued)

3.1. SAFETY (continued)



- Do not cut or dismantle the protection grids.
- Do not transport the compressor when it is working or under pressure.
- Do not modify the machine. Especially puncture holes, weld and voluntarily deform the compressed air reserve.

WORKSPACE

- Maintain the workspace clean and clear.
- Ambient operating temperature must be from 5°C and 35°C.
- Do not use the equipment in a potentially explosive area.
- Do not place any potentially inflammable objects in close proximity to the machine.
- Take away every not qualified person from the working area of the machine, as well as children and animals.
- In case of installation of the machine on scaffolding or a plan above ground level, attach the machine to avoid any fall while operating.
- Do not install the equipment on an inclined surface to avoid the risks of unexpected moves or falls.

HOSES

- Always use hoses and connections adapted to the used product (genuine parts), do not try to fix it.
- Do not walk on the hoses, do not bend them.
- Do not use the hoses to pull the machine.
- Do not use the hoses with other materials, especially materials with higher pressure.

STORAGE

- After every use of the compressor, drain the tank to empty the water inside of it.
- Keep the equipment in a clean and clear area in which the temperature does not exceed +35°C.

IN CASE OF NECESSITY, WE SAVE OURSELVES THE RIGHT TO MAKE ANY USEFUL MODIFICATION WITHOUT ADVANCED NOTICE.

3. WARNING (continued)

3.2. ELECTRIC CONNECTION



The electric connection of the machine must be on a 16A - 230V plug with a differential circuit breaker.

Before any intervention on the machine, make sure that every energy supply is cut (air and electricity).

GROUND CONNECTOR

All the machines must be connected to the ground when they work to protect the operator from electric shocks. Our machines are all equipped with standardized connection plugs.

Electric connection must be made by a qualified technician. It is forbidden to modify or dismantle the machine, especially the electric box.

Repairs must be made by an authorized center or our After-sale Service.

During any intervention on the machine, make sure that the ground is well reconnected.

EXTENSION CORDS

During the use of an extension cord, make sure that it is not crushed or damaged and that it contains a ground. Check that the section of the used extension cord is sufficient to support the machine when it is working. A too thin extension cord can cause voltage drops or overheating of the machine.

In case of use of a cable reel, it is imperative to unwind it entirely, otherwise, the equipment can be damaged. The section must be proportional to the length of the cord.

3.3. END OF LIFE OF THE PRODUCT



At its end-of-life, the machine must not be eliminated with the other household waste. The uncontrolled elimination of waste can harm the environment or human health. Individuals are invited to contact the distributor which sold them the product or to inquire with their city hall to know where and how to get rid of the product so it can be recycled while respecting the environment.

Under the regulation of Waste of Electrical and Electronic Equipments (WEEE), we undertake to process the used EEEs according to the following provisions: applicable only to products on the market since 08/13/05, under the brands EUROPE PROJECTION or VOLUMAIR, products of other brands sold by our company (upon presentation of the corresponding invoices), products that operate using electrical energy (for example, thermal washers or compressors do not fall into this category).

Treatment modality

WEEE returns collected by our clients/distributors at their own expense to our collection points in Antony (92) or Rousset sur Arc (13). Upon receipt, the products are sorted by our employees and directed to the most appropriate processing channels.

For any further information, please contact our hotline to conseil@euromair.com or +33 4 42 29 08 96.

4. YOUR COMPRESSOR

4.1. DESCRIPTIF

The Europro 25 & 27 compressors are ideal for small jobs.

Equipped with 4 rubber feet, a filter regulator protected with a quick-connect coupling, an air output with a quick-connect half-coupling and a pressure switch that controls the air pressure rise in the tank.

These compressors can be used with : spray-guns for slurry products and paint, inflators, staplers...



Do not use the compressor for dietary or medical applications.

In certain applications, the addition of an air dryer and/or oil separator can be necessary.

4.2. TECHNICAL CHARACTERISTICS

	EUROPRO 25	EUROPRO 27
Rotation speed	2850 RPM	2850 RPM
Flow-rate of air absorbed	235 L/min - 14 m ³ /h	284 L/min - 17 m ³ /h
Quantity of oil (crankcase)	0,35 L	0,35 L
Oil consumption	0,5 g/h	0,5 g/h
Motor power	1,8 kW / 2,5 HP	2,2 kW / 3 HP
Electrical supply	230 V	230 V
Frequency	50 Hz	50 Hz
Current	10 A	10 A
Thermal protection	yes	yes
Safety valve	yes	yes
Tank capacity	2 L	2 L
Maximum pressure	10 bar	10 bar
Air coupling	quick-connect	quick-connect
Dimensions (L x w x h)	65 x 36 x 54 cm	55 x 31 x 50 cm
Weight	24 kg	24 kg
Noise level	92 Lwa	92 Lwa

4. YOUR COMPRESSOR (continued)

4.3. IDENTIFICATION OF THE COMPONENTS

EUROPRO 25

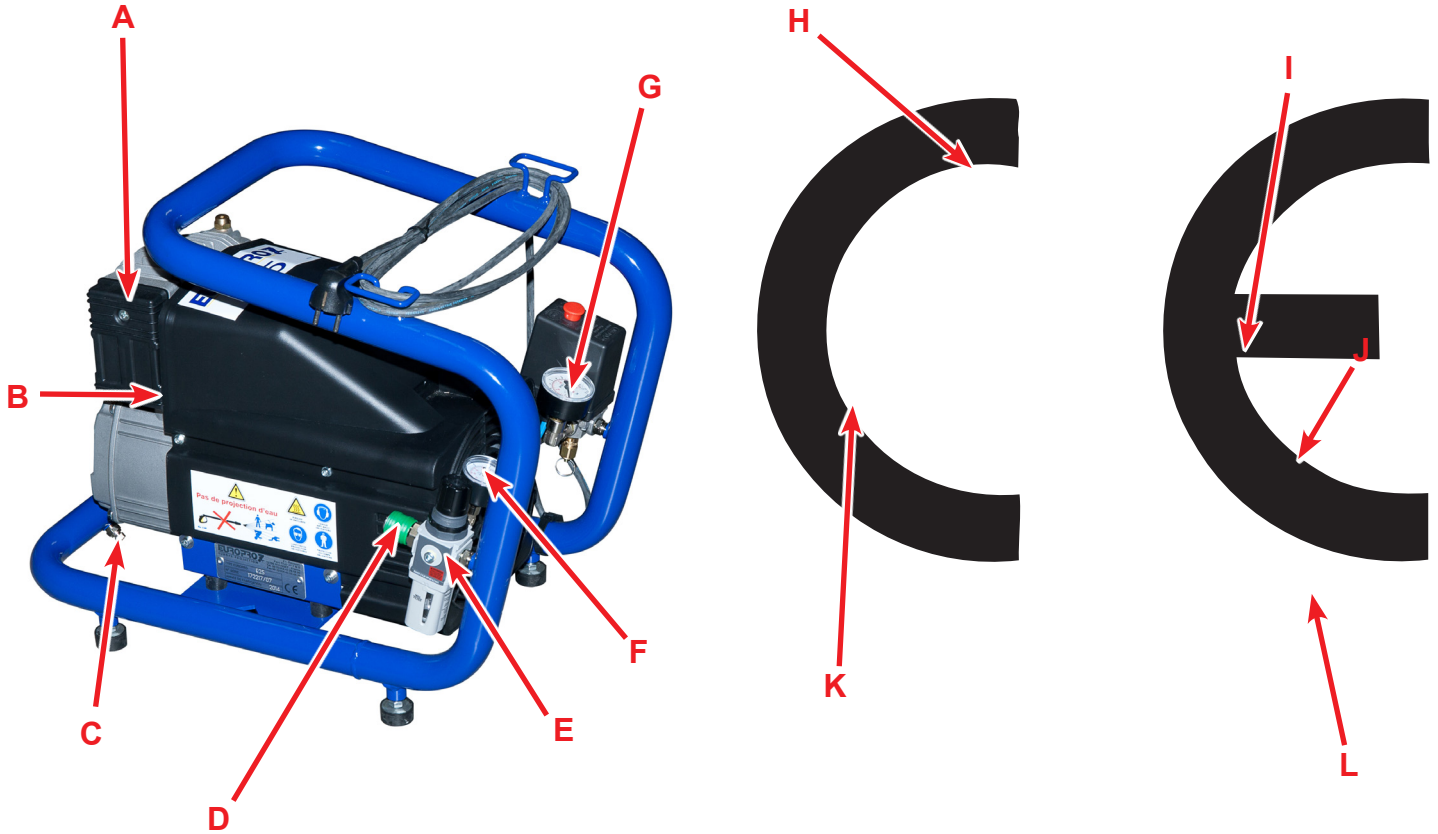

A	Air filter
B	Thermal circuit-breaker
C	Drain screw
D	Female quick-connector 1/4" Ø6
E	Regulator filter 1/4"
F	Air outlet pressure manometer
G	Tank pressure manometer
H	Power cable
I	Compressor head
J	Oil dipstick
K	Pressure switch
L	Drain plug

4. YOUR COMPRESSOR (continued)

4.3. IDENTIFICATION OF THE COMPONENTS

EUROPRO 27

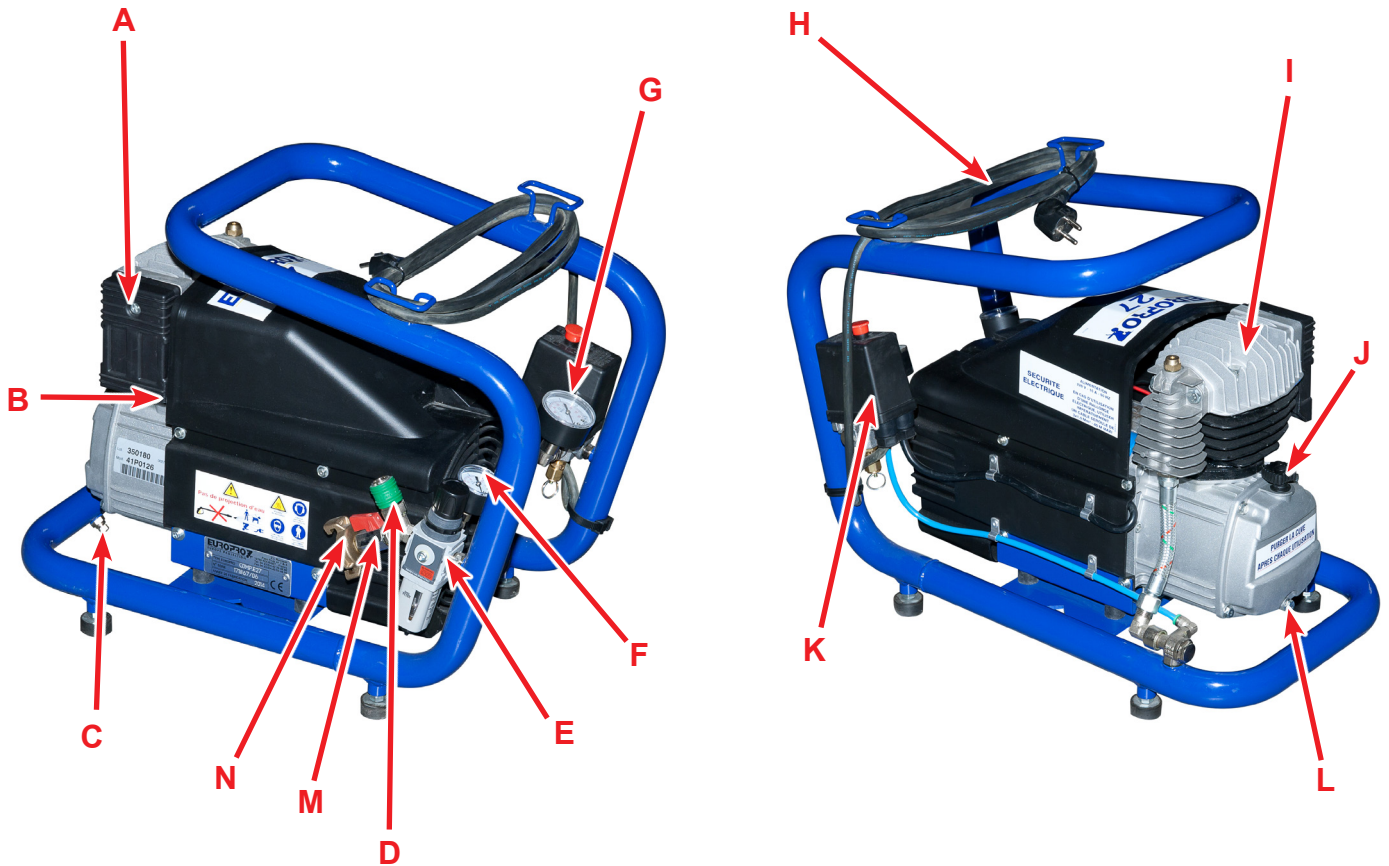

A	Air filter
B	Thermal circuit-breaker
C	Drain screw
D	Female quick-connector 1/4" Ø6
E	Regulator filter 1/4"
F	Air outlet pressure manometer
G	Tank pressure manometer
H	Power cable
I	Compressor head
J	Oil dipstick
K	Pressure switch
L	Drain plug
M	Drain valve
N	Quick-connector 1/4"

5. USE OF THE MACHINE

5.1. PREREQUISITES

- The electric connection has to be 230 V - 16 A - 50 or 60 Hz with a 3 x 2,5 mm cable reel of 40m maximum, completely unreeled.
- The compressor is equipped with a thermal circuit breaker which stops the engine when it has reached a temperature which is too high.
If the compressor fuse has blown wait several minutes to let it cool down, then reset the main circuit breaker by pressing the button (B).

Reduce the length of the electrical cord or use a cable with a bigger cross-section.
If the defect persists, contact our After Sales Service

5.2. STARTING UP



Before every utilization, verify the oil level with the dipstick (J). Refill if needed with the oil ISO 68INH (ref. 80043) until you reach the level "Max" of the dipstick.

1. Drain the air in the tank using the drain screw (C) or the drain valve (M) (Europro 27 compressor only).
2. Connect the compressor electrically.
3. Close the drain screw or valve.
4. Pull up the pressure switch (K) button to start the compressor.
5. Wait until the pressure of the manometer reaches 10 bars. Once this maximum pressure has been reached, the compressor stops*.
6. Set the outlet air pressure with the regulator (E). Pull up the knurl and choose the desired pressure with help of the + and - indicators.
7. Once the outlet air pressure is set, push the knurl back to block the setting.
8. Connect the equipment (spraying machine, spray-gun, etc...) to the compressor on the quick-connector (D) (or the quick-connector (N) for the Europro 27 compressor).
9. Start to use your equipment.

**NB: during the use of the equipment, the pressure in the tank will fall. The motor of the compressor will restart automatically when this pressure will reach 8 bars.*

5.3. STOPPING OF THE COMPRESSOR

1. Detach the equipment linked to the compressor.
2. Open the drain screw and let the compressor for about 2 minutes to evacuate all the condensation which was created in the tank.
3. Push down the red button of the pressure switch (K) to shut down the compressor.
4. Close the drain screw (C).
5. Disconnect electrically the compressor.

6. MAINTENANCE AND SERVICING



Disconnect the plug of the machine from the electrical network before any intervention.

6.1. ONCE PER WEEK

Blasting air filters

Unscrew the air filter (A) and blast it with help of a pressure cleaner.

Cleaning of the filter regulator

1. Unscrew the bowl from the filter regulator an eighth of a turn and pull it down to detach it.
2. Clean the filter and the bowl with help of a sponge.

6.2. EVERY 200 WORKING HOURS

Replace the air filters

Unscrew the air filter (A) and replace it.

Oil change

Contact our After-Sale Service : +33 4 42 29 08 96.



Used oil must not be spilled into the environment or the sewage system, but into a specialized collection site.



In case of the intensive utilization of the compressor, repeat the above mentioned operations more regularly.

7. DEFECTS AND REMEDIES

Defect	Cause	Remedy
The compressor short circuits cuts out	<ul style="list-style-type: none">• Bad power supply• Defective circuit breaker• Defective circuit cutout	<ul style="list-style-type: none">• Reset the circuit breaker or the circuit cutout (replace if necessary)• Verify the current, change the plug on the site• Verify the cross-section of the extension cable
The pressure of the compressor does not go up	<ul style="list-style-type: none">• Filter is clogged up• Drain screw is open• Air leakage• Broken valve plate	<ul style="list-style-type: none">• Replace the filter• Screw up or replace the drain screw• Verify that there is no leakage• Replace the regulator filter• Contact the After-Sale Service
The engine roars but does not start	<ul style="list-style-type: none">• Blown condenser• Lack of oil	<ul style="list-style-type: none">• Replace the condenser• Verify the oil level
The compressor loses pressure	<ul style="list-style-type: none">• Suction filter is clogged up	<ul style="list-style-type: none">• Clean the filter or replace it if it is damaged



In case of an unknown defect or a doubt on the good running of the machine, do not try to repair it by yourself or to dismantle it.

Contact an authorized After-Sale Service or our hotline : +33 4 42 29 08 96.

8. DECLARATION OF CONFORMITY

THE MANUFACTURER : EUROPE PROJECTION
228, avenue Olivier Perroy
13790 ROUSSET

DECLARES THAT THE EQUIPMENT DESIGNATED BELOW :

Trademark : EUROPE PROJECTION

Type : Compressor

Model : EUROPRO 25 or EUROPRO 27

COMPLIES WITH THE ARTICLE:

- the R.233-73 article of the Labour Code

THE DIRECTIVES :

- Machines 2006/42/CE
- Low voltage 2014/35/UE
- CEM 2014/30/UE
- ROHS 2011/65/UE
- Noise emissions 2005/88/CE

AND WITH THE STANDARDS:

- NF EN ISO 12100
- NF EN 60204-1
- NF EN ISO 13857

ROUSSET, JANUARY 20th 2019

Patrick BOREL
President

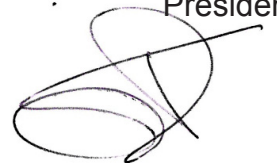

Distributed by : **EUROMAIR DISTRIBUTION**
228, avenue Olivier Perroy 13790 ROUSSET
Tél : +33 (0)4 42 29 08 96 – Fax : +33 (0)4 42 53 44 36
SAS au capital de 400 000€ - SIREN 394 961 510 – NAF 2892 Z

9. WARRANTY

9.1. WARRANTY CONDITIONS

Each product is delivered inspected and tested.

We exclude any warranty for visible defects for which the customer did not claim within 48 hours. The sold equipments are covered by the warranty for the period defined by the manufacturer from the purchase date, onwards the date on the original proof of purchase being valid.

This warranty covers any equipment against any manufacturing or material defect for normal use and service.

The defects or deteriorations caused by natural wear, external accidents or a modification, use, storage or treatment of equipments not planned by the manufacturer, nor specified by ourselves, are excluded from any warranty.

Are expressly excluded from the warranty the defects coming from:

- a bad use
- the application of abrasive or corrosive products
- an inappropriate installation
- negligence
- an insufficient maintenance or cleaning
- chemical, electrochemical or electric influences
- any change in the normal process of use

The following wearing parts are not covered by the warranty:

- rotors, stators, driving shafts, connecting rods, seals, cleaning balls
- spray guns, lance, nozzle, hose, needle kits
- cylinders, piston rods, prime/spray valve assy, seal kits, membranes, suction and delivery valves
- carding machine vanes
- filters, oils

The warranty also excludes the equipments:

- on which the serial number was erased or made illegible
- on which unauthorized people made attempts of repair
- which were totally or partially dismantled

Our equipments are covered by a warranty (parts and labour) of 12 months following the purchase. The duration of this warranty can be extended by 6 months by completing the warranty extension form on our website within 4 weeks after purchasing: www.euromair.com (section «Warranty»)

The defective equipments must be sent at the customer's charge in the place we shall have specified him. The warranty will be subject to the presentation of the invoice. Then we will be able to proceed, free of charge, to the repair of the defective equipment.

The equipments repaired (under warranty) will be shipped free of charge to the customer during the first year of warranty.

Beyond this date, the transport of the repaired equipment will be chargeable to the customer.

In case of intervention of our services on a breakdown caused by the customer or a breakdown excluded in the above-mentioned conditions, the costs of repair and transport will be charged to the customer.

We exclude any responsibility for any consequential damages suffered by the customer, such as, but this without restriction, the losses of income, turnovers, loss of image, of whatever nature.

In any case, our responsibility will be limited to the amount paid by the customer for the defective equipments.

Any action of the customer against us relative to the warranty of the equipments will be prescribed to the deadline of 1 year from the day of the discovery of the cause of the action.

9. WARRANTY (continued)

9.2. CERTIFICATE OF WARRANTY

**IT IS COMPULSARY TO RETURN THIS DOCUMENT DULY COMPLETED
BY E-MAIL : contact@euromair.com OR BY FAX : +33(0)4 42 53 44 36**

IMPERATIVE

The manual must be provided to the user of the equipment.

It must be read before starting up the machine.

For any intervention under warranty, the purchase invoice must be presented.

WARRANTY

Each product is delivered inspected and tested.

Moreover, it is guaranteed for 12 months from the date of purchase.

This guarantee only applies if the buyer respects the safety regulations, contractual and administrative standards and if the use was in conformity with the instructions present in the user manual.

Based on this warranty, the manufacturer will repair or replace free of charge any part that can deteriorate itself or be defective during this period.

The "final judgment" rests solely with our After-Sale Service technicians.

The guarantee does not cover parts which, because of their specific use, are subject to wear and tear.

If the identified defects could not be attributed to our liability, costs will be charged to the buyer.

MODEL : Compressor EUROPRO 25 or EUROPRO 27

SERIAL NUMBER :

DELIVERY NUMBER :

Rousset, dated

Signature of the dealer

Signature of the final user

Stamp of the final user

Distributed by : **EUROMAIR DISTRIBUTION**
228, avenue Olivier Perroy 13790 ROUSSET
Tél : +33 (0)4 42 29 08 96 – Fax : +33 (0)4 42 53 44 36
SAS au capital de 400 000€ - SIREN 394 961 510 – NAF 2892 Z

EUROPE PROJECTION - 228, avenue Olivier Perroy 13790 ROUSSET

Tél : +33 (0)4 42 29 08 96 – Fax : +33 (0)4 42 53 44 36

SAS au capital de 400 000€ - SIREN 394 961 510 – NAF 2892 Z